

MN39242FT

Diagonal 4.5 mm (type-1/4) 570k-pixel CCD Area Image Sensor

■ Overview

The MN39242FT is a 4.5 mm (type-1/4) interline transfer CCD (IT-CCD) solid state image sensor device.

This device uses photodiodes in the optoelectric conversion section and CCDs for signal readout. The electronic shutter function has made an exposure time of 1/10 000 seconds possible. Further, this device has the features of high sensitivity, low noise, broad dynamic range, and low smear.

This device has a total of 566040 pixels (795 horizontal × 712 vertical) and provides stable and clear images with a resolution of 480 horizontal TV-lines and 420 vertical TV-lines.

Part Number	Size	System	Color or B/W
MN39242FT	4.5 mm (type-1/4)	PAL	Color

■ Features

- Effective pixel number: 752 (horizontal) × 697 (vertical)
- High sensitivity
- Broad dynamic range
- Low smear
- Electronic shutter

■ Applications

- Surveillance cameras
- FA, OA cameras

■ Pin Assignments

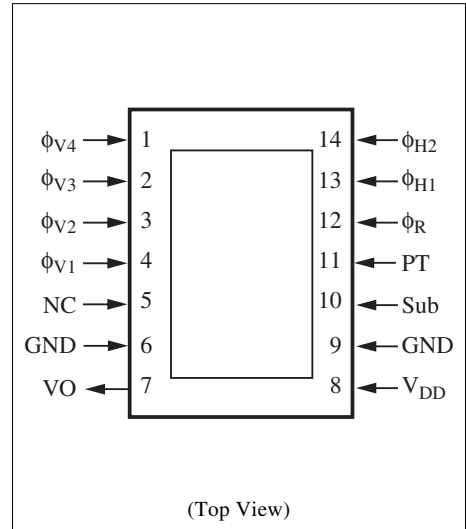

■ Block Diagram

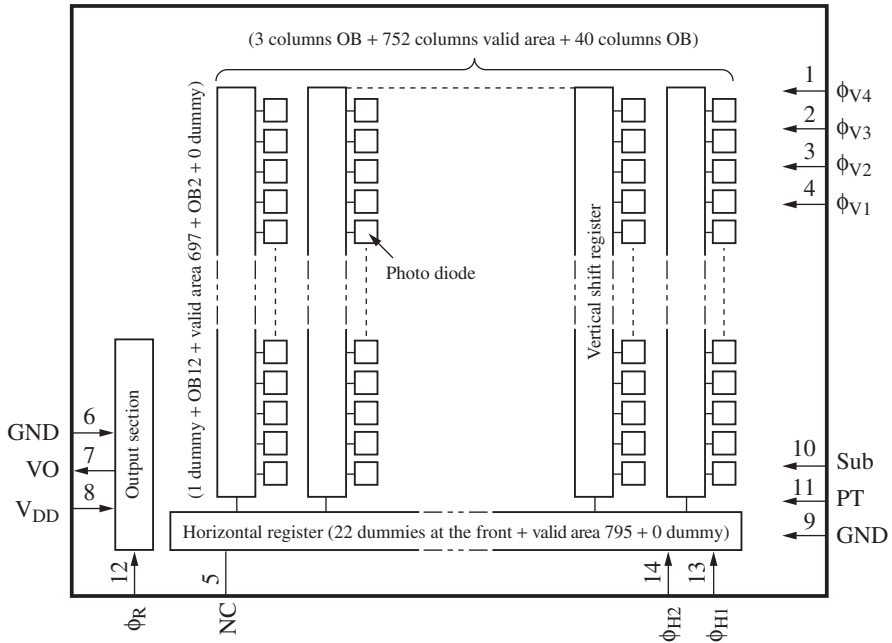

■ Pin Descriptions

Pin No.	Symbol	Description	Pin No.	Symbol	Description
1	ϕ_{V4}	Vertical shift register clock pulse 4	8	V_{DD}	Power supply
2	ϕ_{V3}	Vertical shift register clock pulse 3	9	GND	GND
3	ϕ_{V2}	Vertical shift register clock pulse 2	10	Sub	Substrate
4	ϕ_{V1}	Vertical shift register clock pulse 1	11	PT	P-well for protection circuit
5	NC	NC	12	ϕ_R	Reset pulse
6	GND	GND	13	ϕ_{H1}	Horizontal register clock pulse 1
7	VO	Video output	14	ϕ_{H2}	Horizontal register clock pulse 2

■ Device Parameter (H × V)

Parameter	Value	Unit
Total pixel number	795 × 712	pixel
Active pixel number	737 × 690	pixel
Pixel dimension	4.85 × 3.9	μm^2
Image sensing block dimension	3.65 × 2.72	mm^2

■ Absolute Maximum Ratings and Operating Conditions

Parameter		Absolute maximum rating		Operating condition			Unit
		Lower limit	Upper limit	Min	Typ	Max	
V_{DD}		-0.2	18.0	14.5	15.0	15.5	V
$V_{PT}^{*3,4}$		-10.0	0.2	-7.5	-7.0	-6.5	V
GND		(Reference voltage)		—	0	—	V
$V_{\phi R}$	High-Low	—	8.0	3.0	3.3	3.6	V
	Bias	(Supplied internally)					V
$V_{\phi H1}$	High	—	8.0	3.0	3.3	3.6	V
	Low	-0.2	—	-0.05	0	0.05	V
$V_{\phi H2}$	High	—	8.0	3.0	3.3	3.6	V
	Low	-0.2	—	-0.05	0	0.05	V
V_{Sub}^{*2}		(Supplied internally)					V
ϕV_{Sub}^{*1}		-0.2	45.0	21.2	22.0	22.8	V
$V_{\phi V1}^{*3,4}$	High	—	18.0	14.5	15.0	15.5	V
	Middle	—	—	-0.05	0	0.05	V
	Low	-9.0	—	-7.3	-7.0	-6.7	V
$V_{\phi V2}^{*3,4}$	Middle	—	15.0	-0.05	0	0.05	V
	Low	-9.0	—	-7.3	-7.0	-6.7	V
$V_{\phi V3}^{*3,4}$	High	—	18.0	14.5	15.0	15.5	V
	Middle	—	—	-0.05	0	0.05	V
	Low	-9	—	-7.3	-7.0	-6.7	V
$V_{\phi V4}^{*3,4}$	Middle	—	15.0	-0.05	0	0.05	V
	Low	-9.0	—	-7.3	-7.0	-6.7	V
Operating temperature		-10	70	—	25	—	°C
Storage temperature		-30	80	—	—	—	°C

Note) 1. Standard photo detecting condition

Standard photo detecting condition stands for detecting image with a light source of color temperature of 2856K, luminance of 1050 cd/m², and using a color temperature conversion filter LB-40 (HOYA), infrared cut filter CAW-500S with thickness 2.5 mm for a light path and with F8 lens aperture. The quantity of the incidental light to a photo-detecting surface under the above condition is defined as the standard quantity of light.

2. *1: V_{Sub} when using electronic shutter function

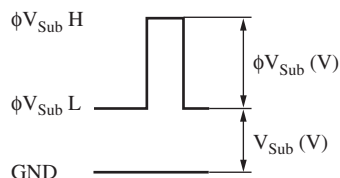

*2: V_{Sub} supplied internally is the voltage suppressing the blooming generation at $\times 1000$ light quantity relative to the standard light quantity.

*3: Relation between V_{PT} and $V_{\phi VL}$

Set V_{PT} under the following condition against VL of a vertical transfer clock waveform.

$$V_{PT} \leq VL (V_{\phi V1L} \text{ to } V_{\phi V4L})$$

*4: Absolute maximum ratings $-0.2 < V_{\phi V} - V_{PT} < 24.5 (V)$

■ Optical Characteristics

Parameter	Symbol	Conditions	Min	Typ	Max	Unit
S/N ratio (dark)	S/Nd	Dark condition	59	61	—	dB
Sensitivity	So	J chart F8	160	190	—	mV
Carrier saturation output	Sa	Carrier maximum output	400	500	—	mV
Vertical smear	Sm	1/10 V chart, F2.8	—	0.008	0.01	%

■ Graph of Characteristics

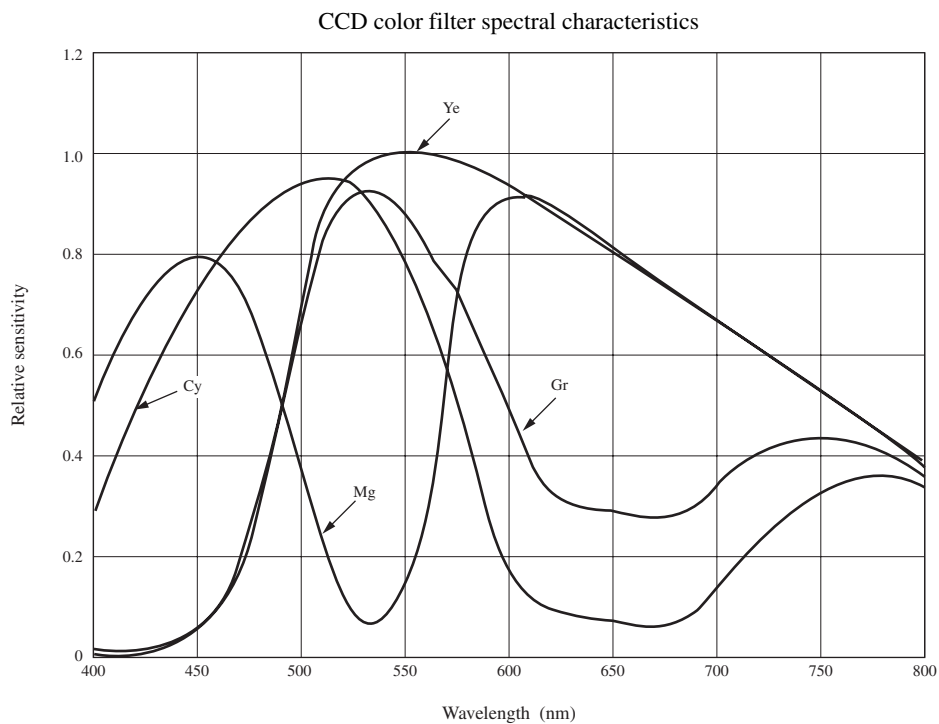

■ CCD Drive Timing Charts

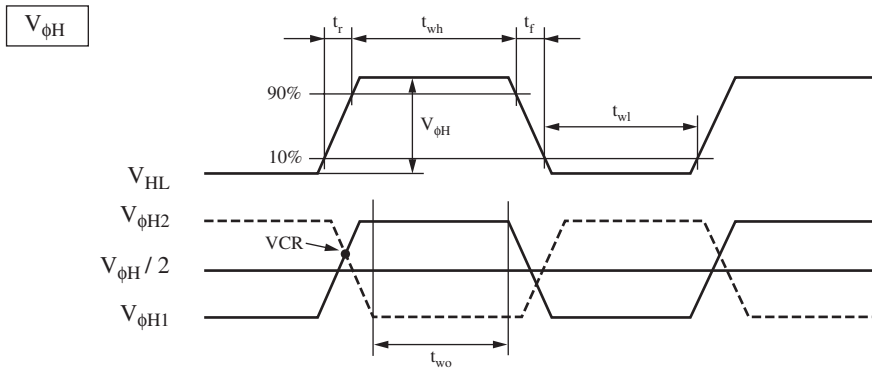

The overlap period of t_{wh} of horizontal transfer pulse $V_{\phi H1}$ and t_{wl} of $V_{\phi H2}$ and the overlap period of t_{wl} of horizontal transfer pulse $V_{\phi H1}$ and t_{wh} of $V_{\phi H2}$ are defined as t_{wo} .
And VCR is the cross point voltage of the rising $V_{\phi H1}$ and the falling $V_{\phi H2}$.

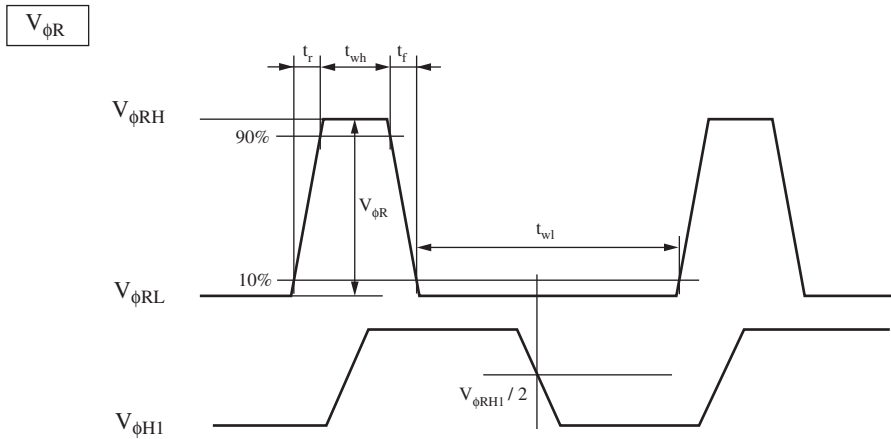

$V_{\phi RL}$ is the mean value of the waveform from the cross point of the mesial magnitude of above ϕ_{H1} and ϕ_{R1w1} period to the rising point.
And $V_{\phi RH}$ is the minimum value in t_{wh} period, and $V_{\phi R}$ is defined as $V_{\phi R} = V_{\phi RH} - V_{\phi RL}$.

Parameter	Symbol	t_{wh}			t_{wl}			t_r			t_f			Unit
		Min	Typ	Max	Min	Typ	Max	Min	Typ	Max	Min	Typ	Max	
Reset pulse	$V_{\phi R}$	9.0	10.0		46.5	47.5			3.0	4.0		3.0	4.0	ns
Horizontal transfer pulse	$V_{\phi H1}$	23.75	25.75		23.75	25.75			6.0	8.0		6.0	8.0	ns
	$V_{\phi H2}$	23.75	25.75		23.75	25.75			6.0	8.0		6.0	8.0	ns

VCR is $V_{\phi H} / 2$ volts or more.

Parameter	Symbol	t_{wo}			Unit
		Min	Typ	Max	
Horizontal transfer pulse	$V_{\phi H1}, V_{\phi H2}$	20.75	25.75	—	ns

■ Package Dimensions (unit: mm)

- WDIP014P-0400F

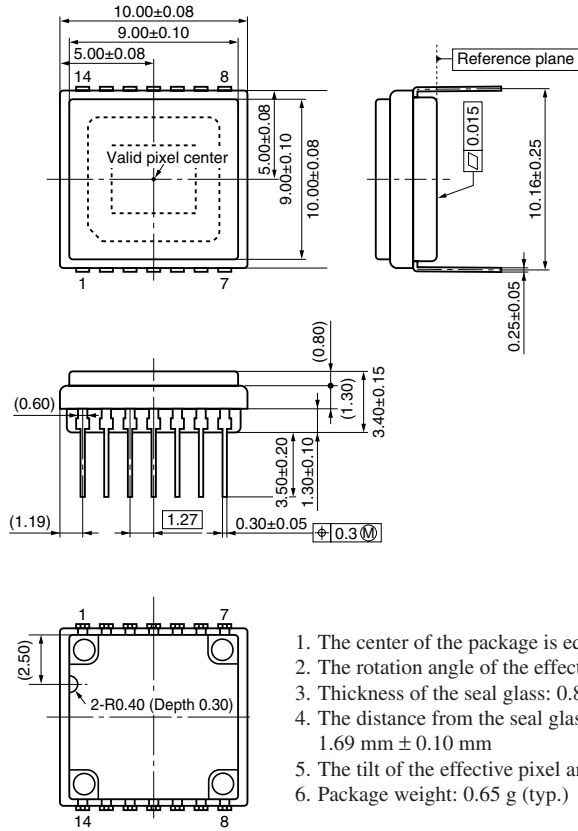

1. The center of the package is equal to the center of the effective pixel area.
2. The rotation angle of the effective pixel area: up to ± 1.0 degree
3. Thickness of the seal glass: 0.8 mm, and the refractive index: 1.50
4. The distance from the seal glass surface to the surface of the effective pixel area: $1.69 \text{ mm} \pm 0.10 \text{ mm}$
5. The tilt of the effective pixel area for the seal glass surface: up to $25 \mu\text{m}$
6. Package weight: 0.65 g (typ.)

Request for your special attention and precautions in using the technical information and semiconductors described in this material

- (1) An export permit needs to be obtained from the competent authorities of the Japanese Government if any of the products or technologies described in this material and controlled under the "Foreign Exchange and Foreign Trade Law" is to be exported or taken out of Japan.
- (2) The technical information described in this material is limited to showing representative characteristics and applied circuit examples of the products. It does not constitute the warranting of industrial property, the granting of relative rights, or the granting of any license.
- (3) The products described in this material are intended to be used for standard applications or general electronic equipment (such as office equipment, communications equipment, measuring instruments and household appliances).
Consult our sales staff in advance for information on the following applications:
 - Special applications (such as for airplanes, aerospace, automobiles, traffic control equipment, combustion equipment, life support systems and safety devices) in which exceptional quality and reliability are required, or if the failure or malfunction of the products may directly jeopardize life or harm the human body.
 - Any applications other than the standard applications intended.
- (4) The products and product specifications described in this material are subject to change without notice for reasons of modification and/or improvement. At the final stage of your design, purchasing, or use of the products, therefore, ask for the most up-to-date Product Standards in advance to make sure that the latest specifications satisfy your requirements.
- (5) When designing your equipment, comply with the guaranteed values, in particular those of maximum rating, the range of operating power supply voltage and heat radiation characteristics. Otherwise, we will not be liable for any defect which may arise later in your equipment.
Even when the products are used within the guaranteed values, redundant design is recommended, so that such equipment may not violate relevant laws or regulations because of the function of our products.
- (6) When using products for which dry packing is required, observe the conditions (including shelf life and after-unpacking standby time) agreed upon when specification sheets are individually exchanged.
- (7) No part of this material may be reprinted or reproduced by any means without written permission from our company.

Please read the following notes before using the datasheets

- A. These materials are intended as a reference to assist customers with the selection of Panasonic semiconductor products best suited to their applications.
Due to modification or other reasons, any information contained in this material, such as available product types, technical data, and so on, is subject to change without notice.
Customers are advised to contact our semiconductor sales office and obtain the latest information before starting precise technical research and/or purchasing activities.
- B. Panasonic is endeavoring to continually improve the quality and reliability of these materials but there is always the possibility that further rectifications will be required in the future. Therefore, Panasonic will not assume any liability for any damages arising from any errors etc. that may appear in this material.
- C. These materials are solely intended for a customer's individual use.
Therefore, without the prior written approval of Panasonic, any other use such as reproducing, selling, or distributing this material to a third party, via the Internet or in any other way, is prohibited.